

Gople Mini Suspension - White/White

BIG - Bjarke Ingels Group

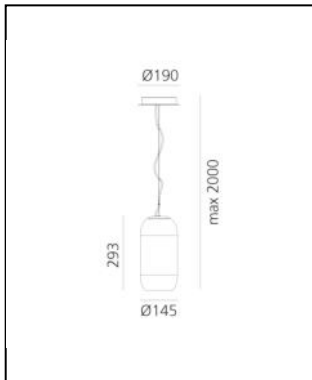

IP20    Dimmbar: 



LUMINAIRE

- Watt: **5W**
- Lichtstrom (lm): **440lm**
- Efficiency: **94%**
- Efficacy: **87.91lm/W**
- CRI: **80**

Anmerkungen

BESCHREIBUNG

The basic form of the Gople Lamp enhances the beauty of glass, hand-processed according to an ancient Venetian technique that gradually turns white glass into crystal glass by combining both upon blowing, thus making each piece unique. More innovative finishes are added, including silver or copper vacuum metallization.

Silver, bronze, copper and blue finishes are made with an innovative and sustainable metal vacuum deposition process. From the point of view of environmental-friendliness, "sputtering" is the absolutely cleanest coating technology for the type of metal used and because all emissions are abated, in particular those into the atmosphere of sulphuric acid and cyanides produced by galvanic processes.

Solid paint with up to 5% of solvents (compared to 75% of traditional products) is employed for the successive protective clearcoat phase.

The process generates very little waste and the resulting finish is particularly resistant over time. In any of these cases, glass finishing is designed to ensure the best relation with the emitted light, screening the source and maximizing direct emission through transparency. The most basic version with the traditional E27 or E14 joint is designed to provide different performance levels compared to the more innovative RWB version, where colours can be combined with each other to create lightscapes that meet space requirements. It is a timeless solution for its flexibility in adjusting to the development of standard source technologies.

ARTIKELNUMMER: 1406220A

FUNKTIONEN

- Artikelnummer: **1406220A**
- Farbe: **White/White**
- Installation: **Pendelleuchte**
- Material: **Blown glass, aluminium**
- Serie: **Design Collection**
- Anwendungsbereich: **Innenbeleuchtung**
- design: **BIG - Bjarke Ingels Group**

DIMENSION

- Höhe: **cm 30**
- Breite: **cm 14.5**
- Durchmesser Fuß: **cm 16.5**
- Max Höhe von der Decke: **cm 200**

LICHTQUELLEN NICHT ENHALTEN

- Kategorie: **LED RETROFIT**
- Anzahl: **1**
- Watt: **6W**
- Sockel: **E14**

Gople Mini Suspension - Silver

BIG - Bjarke Ingels Group



IP20    Dimmbar: 

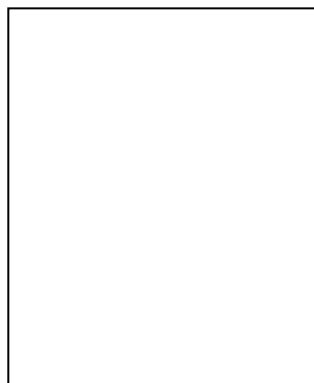
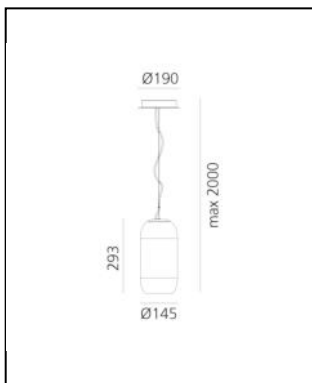

LUMINAIRE

- Watt: **5W**
- Lichtstrom (lm): **272lm**
- Efficiency: **58%**
- Efficacy: **54.43lm/W**
- CRI: **80**

BESCHREIBUNG

The basic form of the Gople Lamp enhances the beauty of glass, hand-processed according to an ancient Venetian technique that gradually turns white glass into crystal glass by combining both upon blowing, thus making each piece unique. More innovative finishes are added, including silver or copper vacuum metallization.

Silver, bronze, copper and blue finishes are made with an innovative and sustainable metal vacuum deposition process. From the point of view of environmental-friendliness, "sputtering" is the absolutely cleanest coating technology for the type of metal used and because all emissions are abated, in particular those into the atmosphere of sulphuric acid and cyanides produced by galvanic processes.

Solid paint with up to 5% of solvents (compared to 75% of traditional products) is employed for the successive protective clearcoat phase.

The process generates very little waste and the resulting finish is particularly resistant over time. In any of these cases, glass finishing is designed to ensure the best relation with the emitted light, screening the source and maximizing direct emission through transparency. The most basic version with the traditional E27 or E14 joint is designed to provide different performance levels compared to the more innovative RWB version, where colours can be combined with each other to create lightscapes that meet space requirements. It is a timeless solution for its flexibility in adjusting to the development of standard source technologies.

ARTIKELNUMMER: 1406010A

FUNKTIONEN

- Artikelnummer: **1406010A**
- Farbe: **Silver**
- Installation: **Pendelleuchte**
- Material: **Blown glass, aluminium**
- Serie: **Design Collection**
- Anwendungsbereich: **Innenbeleuchtung**
- design: **BIG - Bjarke Ingels Group**

DIMENSION

- Höhe: **cm 30**
- Breite: **cm 14.5**
- Durchmesser Fuß: **cm 16.5**
- Max Höhe von der Decke: **cm 200**

LICHTQUELLEN NICHT ENHALTEN

- Kategorie: **LED RETROFIT**
- Anzahl: **1**
- Watt: **6W**
- Sockel: **E14**

Gople Mini Suspension - Black/Copper

BIG - Bjarke Ingels Group



IP20    Dimmbar: 

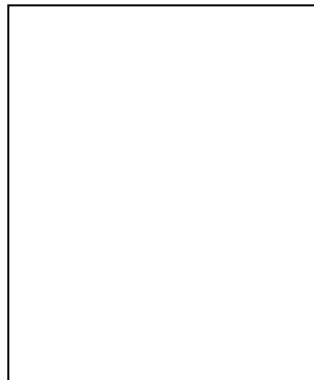
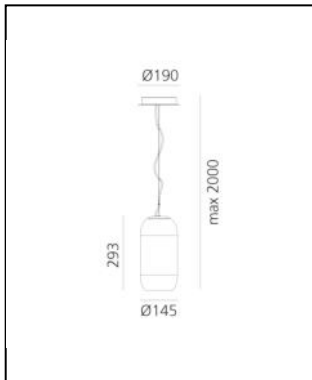

LUMINAIRE

- Watt: **5W**
- Lichtstrom (lm): **236lm**
- Efficiency: **50%**
- Efficacy: **47.15lm/W**
- CRI: **80**

BESCHREIBUNG

The basic form of the Gople Lamp enhances the beauty of glass, hand-processed according to an ancient Venetian technique that gradually turns white glass into crystal glass by combining both upon blowing, thus making each piece unique. More innovative finishes are added, including silver or copper vacuum metallization.

Silver, bronze, copper and blue finishes are made with an innovative and sustainable metal vacuum deposition process. From the point of view of environmental-friendliness, "sputtering" is the absolutely cleanest coating technology for the type of metal used and because all emissions are abated, in particular those into the atmosphere of sulphuric acid and cyanides produced by galvanic processes.

Solid paint with up to 5% of solvents (compared to 75% of traditional products) is employed for the successive protective clearcoat phase.

The process generates very little waste and the resulting finish is particularly resistant over time. In any of these cases, glass finishing is designed to ensure the best relation with the emitted light, screening the source and maximizing direct emission through transparency. The most basic version with the traditional E27 or E14 joint is designed to provide different performance levels compared to the more innovative RWB version, where colours can be combined with each other to create lightscapes that meet space requirements. It is a timeless solution for its flexibility in adjusting to the development of standard source technologies.

ARTIKELNUMMER: 1406340A

FUNKTIONEN

- Artikelnummer: **1406340A**
- Farbe: **Black/Copper**
- Installation: **Pendelleuchte**
- Material: **Blown glass, aluminium**
- Serie: **Design Collection**
- Anwendungsbereich: **Innenbeleuchtung**
- design: **BIG - Bjarke Ingels Group**

DIMENSION

- Höhe: **cm 30**
- Breite: **cm 14.5**
- Durchmesser Fuß: **cm 16.5**
- Max Höhe von der Decke: **cm 200**

LICHTQUELLEN NICHT ENHALTEN

- Kategorie: **LED RETROFIT**
- Anzahl: **1**
- Watt: **6W**
- Sockel: **E14**

Gople Mini Suspension - Black/Bronze

BIG - Bjarke Ingels Group



IP20    Dimmbar: 

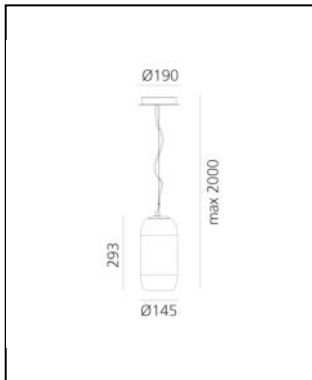

LUMINAIRE

- Watt: **5W**
- Lichtstrom (lm): **236lm**
- Efficiency: **50%**
- Efficacy: **47.15lm/W**
- CRI: **80**

BESCHREIBUNG

The basic form of the Gople Lamp enhances the beauty of glass, hand-processed according to an ancient Venetian technique that gradually turns white glass into crystal glass by combining both upon blowing, thus making each piece unique. More innovative finishes are added, including silver or copper vacuum metallization.

Silver, bronze, copper and blue finishes are made with an innovative and sustainable metal vacuum deposition process. From the point of view of environmental-friendliness, "sputtering" is the absolutely cleanest coating technology for the type of metal used and because all emissions are abated, in particular those into the atmosphere of sulphuric acid and cyanides produced by galvanic processes.

Solid paint with up to 5% of solvents (compared to 75% of traditional products) is employed for the successive protective clearcoat phase.

The process generates very little waste and the resulting finish is particularly resistant over time. In any of these cases, glass finishing is designed to ensure the best relation with the emitted light, screening the source and maximizing direct emission through transparency. The most basic version with the traditional E27 or E14 joint is designed to provide different performance levels compared to the more innovative RWB version, where colours can be combined with each other to create lightscapes that meet space requirements. It is a timeless solution for its flexibility in adjusting to the development of standard source technologies.

ARTIKELNUMMER: 1406360A

FUNKTIONEN

- Artikelnummer: **1406360A**
- Farbe: **Black/Bronze**
- Installation: **Pendelleuchte**
- Material: **Blown glass, aluminium**
- Serie: **Design Collection**
- Anwendungsbereich: **Innenbeleuchtung**
- design: **BIG - Bjarke Ingels Group**

DIMENSION

- Höhe: **cm 30**
- Breite: **cm 14.5**
- Durchmesser Fuß: **cm 16.5**
- Max Höhe von der Decke: **cm 200**

LICHTQUELLEN NICHT ENHALTEN

- Kategorie: **LED RETROFIT**
- Anzahl: **1**
- Watt: **6W**
- Sockel: **E14**

Gople Mini Suspension - Black/Blue

BIG - Bjarke Ingels Group



IP20    Dimmbar: 

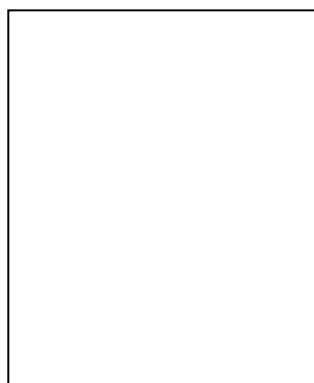
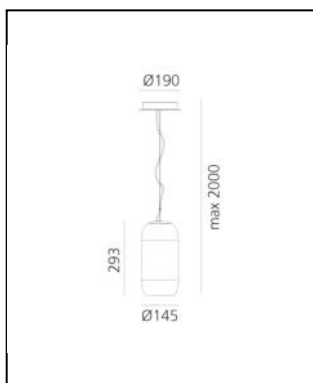

LUMINAIRE

- Watt: **5W**
- Lichtstrom (lm): **272lm**
- Efficiency: **58%**
- Efficacy: **54.43lm/W**
- CRI: **80**

Anmerkungen

BESCHREIBUNG

The basic form of the Gople Lamp enhances the beauty of glass, hand-processed according to an ancient Venetian technique that gradually turns white glass into crystal glass by combining both upon blowing, thus making each piece unique. More innovative finishes are added, including silver or copper vacuum metallization.

Silver, bronze, copper and blue finishes are made with an innovative and sustainable metal vacuum deposition process. From the point of view of environmental-friendliness, "sputtering" is the absolutely cleanest coating technology for the type of metal used and because all emissions are abated, in particular those into the atmosphere of sulphuric acid and cyanides produced by galvanic processes.

Solid paint with up to 5% of solvents (compared to 75% of traditional products) is employed for the successive protective clearcoat phase.

The process generates very little waste and the resulting finish is particularly resistant over time. In any of these cases, glass finishing is designed to ensure the best relation with the emitted light, screening the source and maximizing direct emission through transparency. The most basic version with the traditional E27 or E14 joint is designed to provide different performance levels compared to the more innovative RWB version, where colours can be combined with each other to create lightscapes that meet space requirements. It is a timeless solution for its flexibility in adjusting to the development of standard source technologies.

ARTIKELNUMMER: 1406350A

FUNKTIONEN

- Artikelnummer: **1406350A**
- Farbe: **Black/Blue**
- Installation: **Pendelleuchte**
- Material: **Blown glass, aluminium**
- Serie: **Design Collection**
- Anwendungsbereich: **Innenbeleuchtung**
- design: **BIG - Bjarke Ingels Group**

DIMENSION

- Höhe: **cm 30**
- Breite: **cm 14.5**
- Durchmesser Fuß: **cm 16.5**
- Max Höhe von der Decke: **cm 200**

LICHTQUELLEN NICHT ENHALTEN

- Kategorie: **LED RETROFIT**
- Anzahl: **1**
- Watt: **6W**
- Sockel: **E14**